

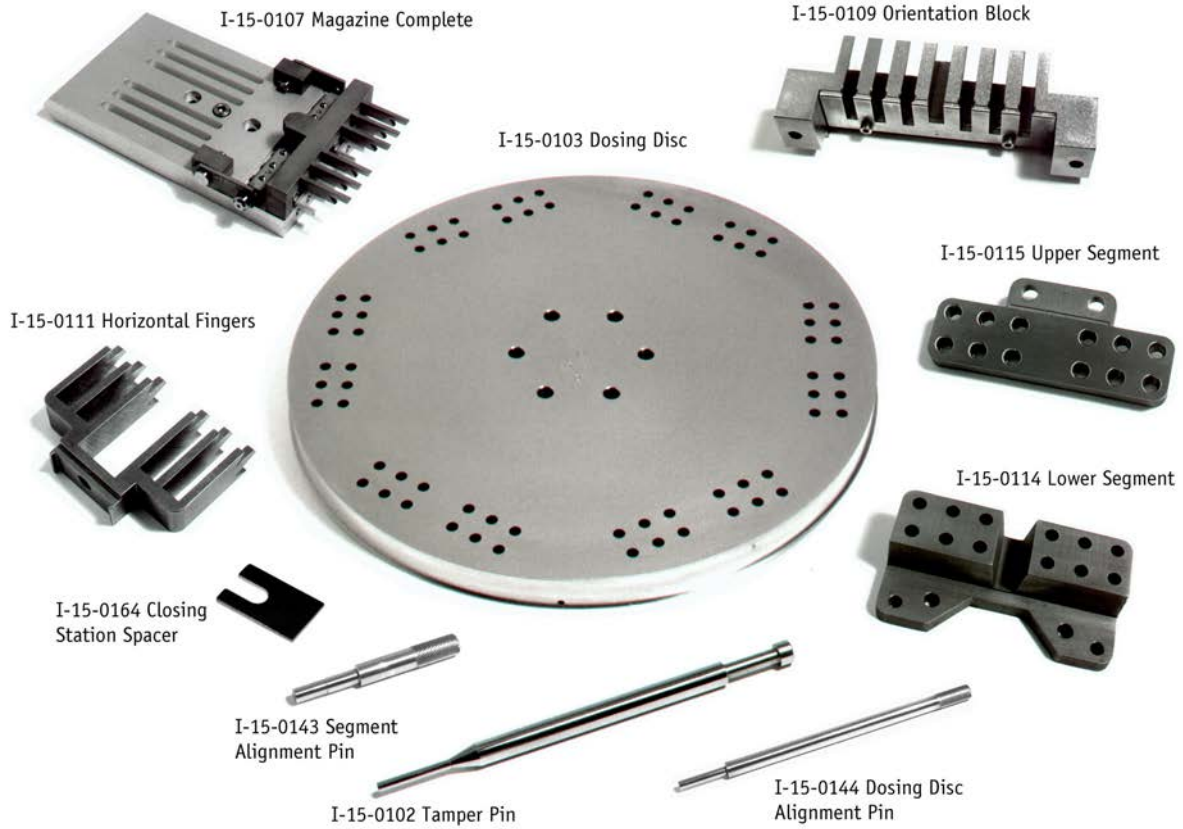

Index 12 CT Series Encapsulator

Model K90i, H&K 1500, GKF 1500
Spare Part and Tooling Catalog

12 CT TOOLING SET



Item No.	Description	Qty in Set
I-15-0102	Tamper Pin	72
I-15-0103	Dosing Disc	1
I-15-0107	Magazine Complete	2
I-15-0111	Horizontal Fingers	2
I-15-0109	Orientation Block	2
I-15-0115	Upper Segment	12
I-15-0114	Lower Segment	12
I-15-0143	Segment Alignment Pin	2
I-15-0144	Dosing Disc Alignment Pin	2
I-15-0164	Closing Station Spacer	1

I-15-0000-x Complete Format Set (Specify Size)



I-15-0102-size

**Tamping Pin, Sz x
72 per set**



I-15-0103-X-X.X

Dosing Disc, 12 CT, Sz x, x.x mm

Not included in tooling set

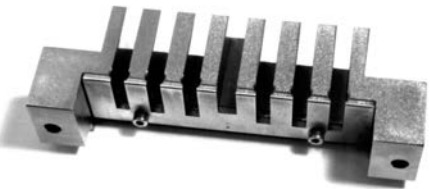

I-15-0109-size

**Orientation Block, 12 CT, Sz x
2 per set**



I-15-0111-x

**Horizontal Finger, 12 CT, Sz x
2 per set**



I-15-0114-x

**Lower Segment, 12 CT, Sz x
12 per set**

(Old Style Pictured)



I-15-0115-x

**Upper Segment, 12 CT, Sz x
12 per set**

(Old Style Pictured)



I-15-0143-x

**Segment Alignment Pin, Sz x
2 per set**



I-15-0144-x

**Dosing Disc Alignment Pin, Sz x
2 per set**



I-15-0164

**Closing Station Spacer, Sz x
1 per set**

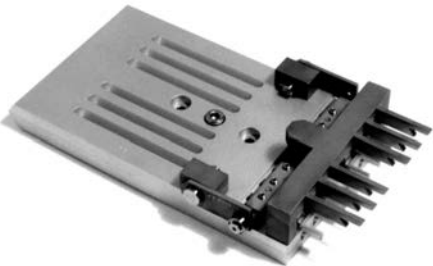

I-15-0107-x

**Magazine Complete, 12 CT, Sz x
2 per set**

Price Each \$1,700.00

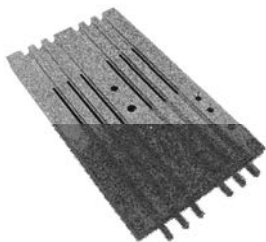

I-15-0107F-size

**Magazine Front, 12 CT, Sz x
2 per set**



I-15-0107R-size

**Magazine Rear, 12 CT, Sz x
2 per set**



I-15-0107VF-size

**Vertical Fingers, 12 CT, Sz x
2 per set of tooling; 1 per
magazine**



I-15-0108

**Magazine Leaf Spring Assembly,
12 CT
2 per machine**



I-15-0108LS

**Leaf Spring
12 per machine; 6 per assembly**

STATIONS SET UP

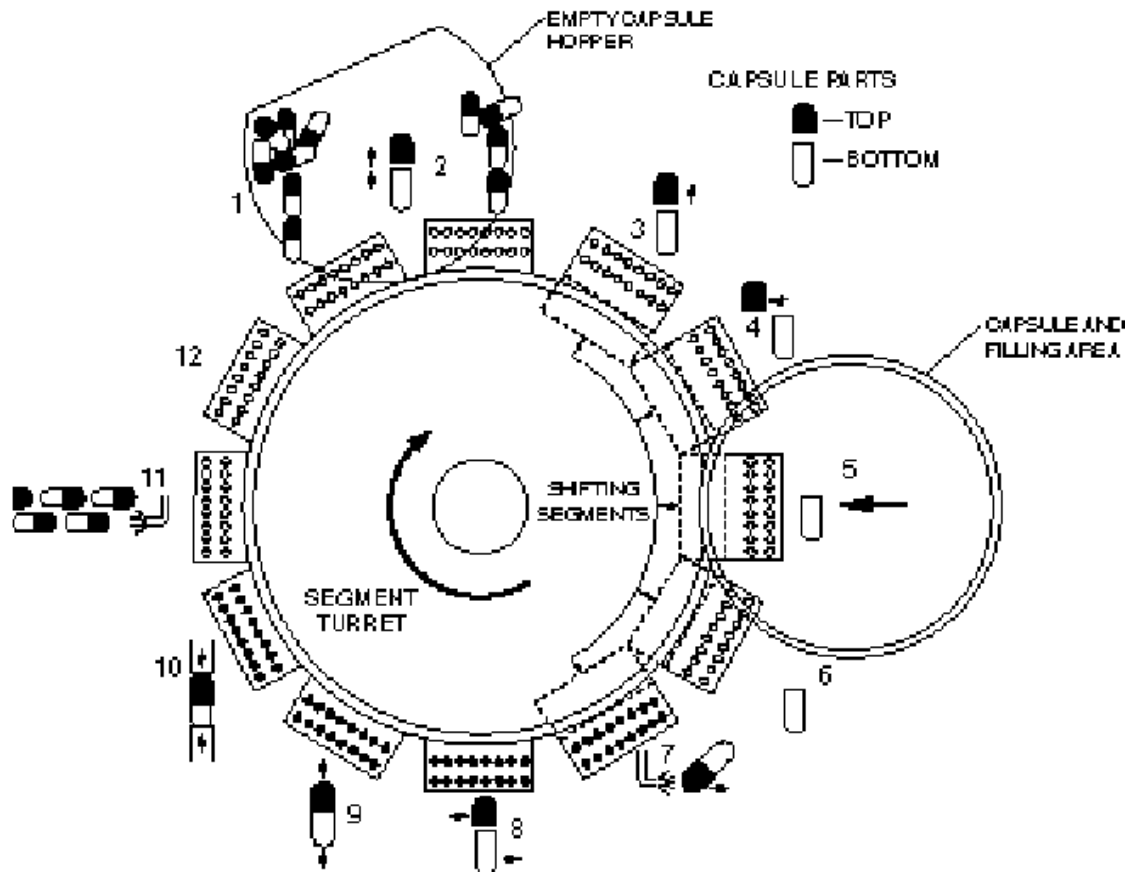

STATIONS	
1 & 2	CAPSULE FEED, LOADING, AND SEPARATION
3	SEGMENT SEPARATION (VERTICAL SHIFT)
4	CAP REMOVAL (HORIZONTAL SHIFT)
5	POWDER DOSING STATION
6	OPEN (NOT USED)
7	UNSEPARATED (FAULTY) CAPSULE EJECTION
8	REALIGNMENT OF CAPSULES (HORIZONTAL SHIFT)
9	SEGMENT COMBINATION (VERTICAL SHIFT)
10	CLOSING STATION
11	EJECTION STATION (FINISHED PRODUCT)
12	HIGH INTENSITY SEGMENT CLEANING STATION

SORTING AND SEPARATION

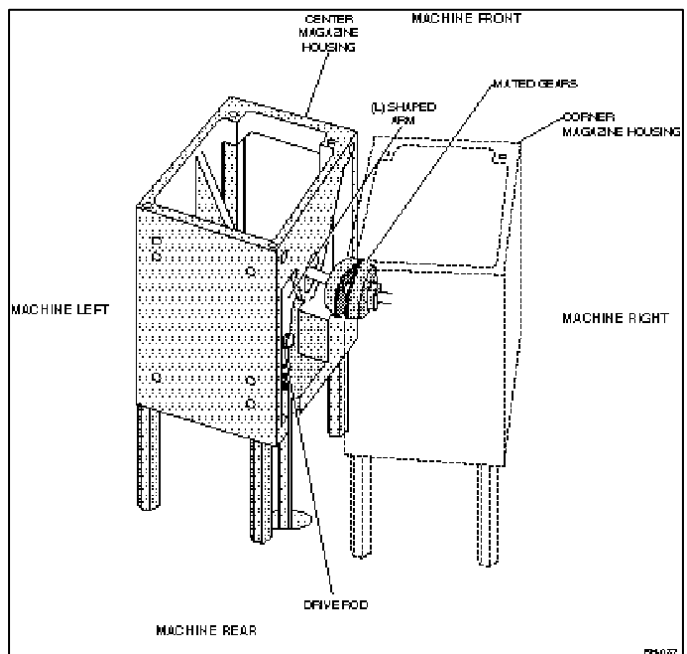
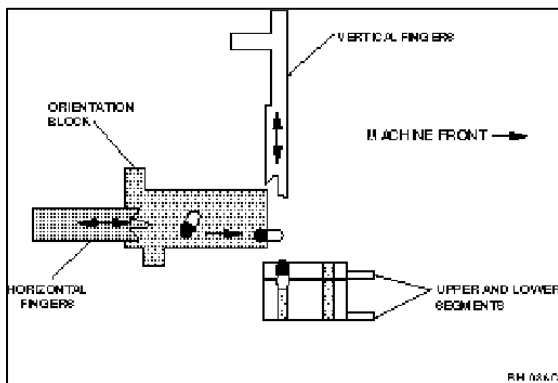
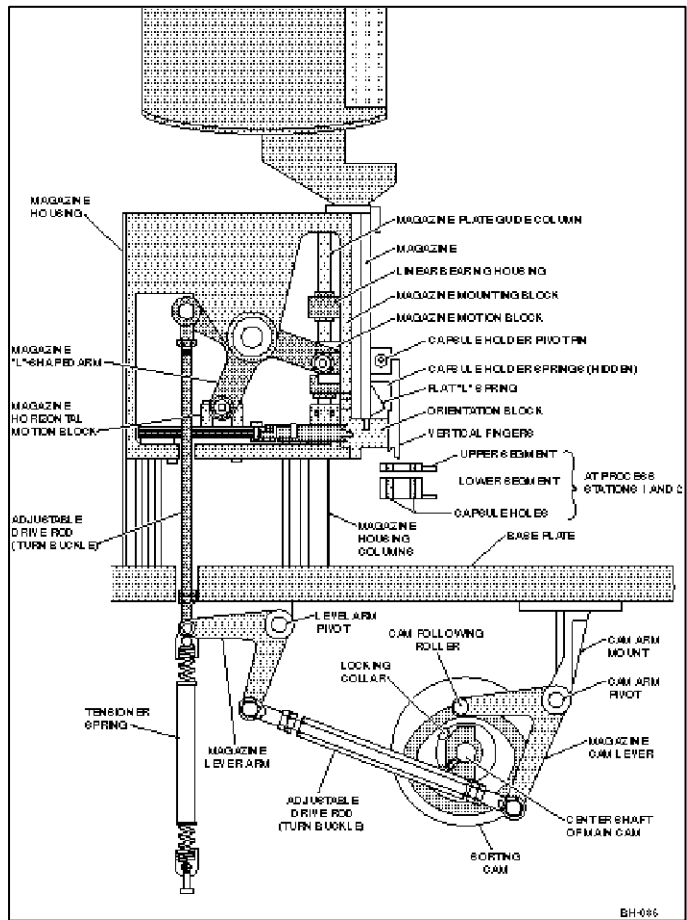
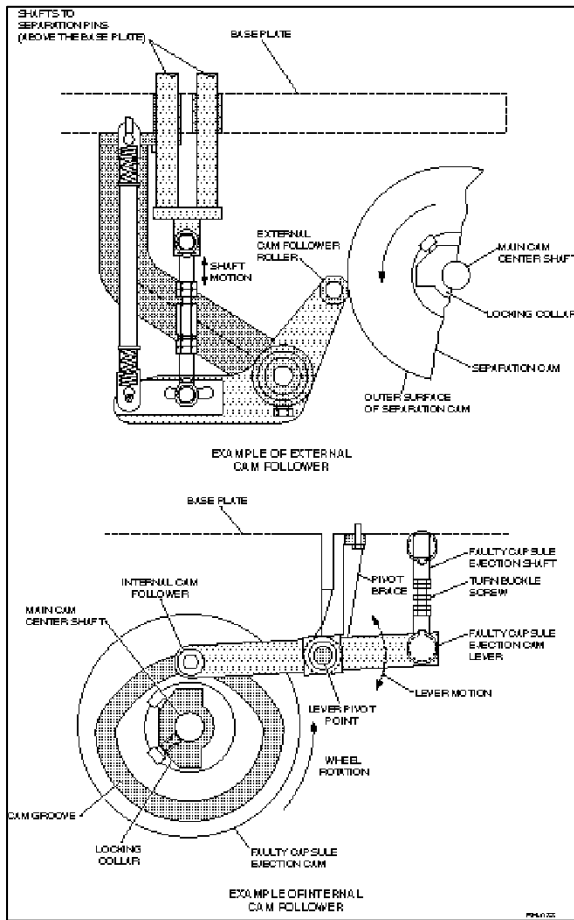

SORTING AND SEPARATION

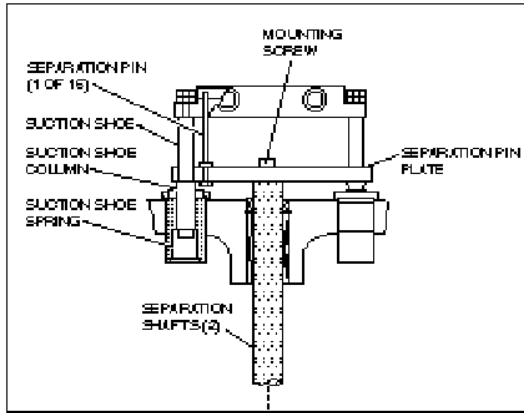

REAR-SIDE VIEW OF SEPARATION PINS

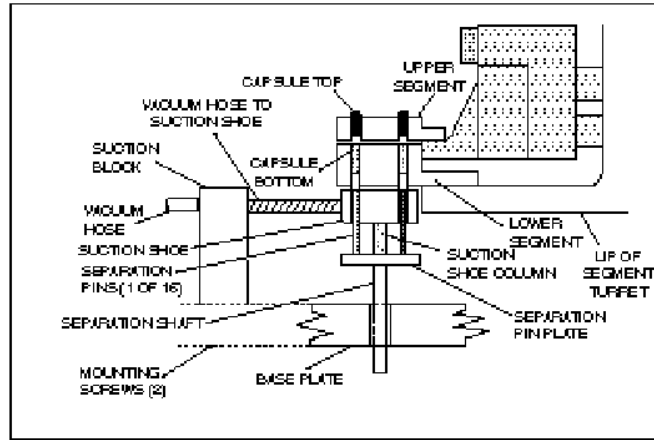

LEFT-SIDE VIEW OF SEPARATION PINS

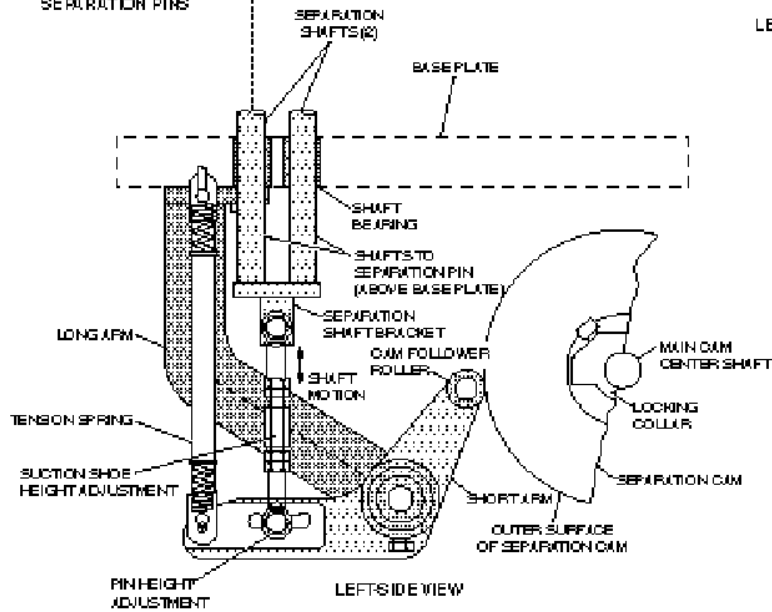

LEFTSIDE VIEW

EN-0028

SEPARATION

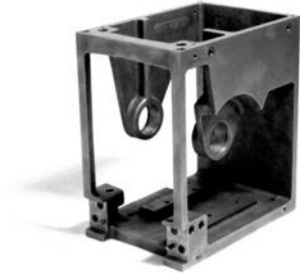

I-15-1103L or R

**Magazine Housing Left or Right
1 each per machine**



I-15-1019L

**Magazine Bevel Gear Left
1 per machine**



I-15-1019R

**Magazine Bevel Gear Right
1 per machine**

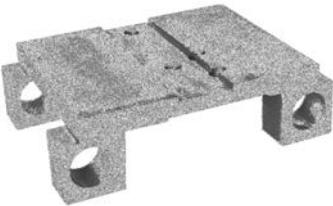

I-15-0158

**Magazine Mount Block
2 per machine**



I-15-1079

**Magazine Activating Arm
2 per machine**

SEPARATION



I-15-0159

**Magazine Motion Block
4 per machine**



I-15-1017

**Bearing Slide Plate
2 per machine**



I-15-1605

**ES-5 Slide
4 per machine**

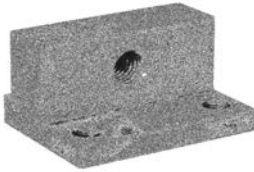

I-15-1037

**Horizontal Finger Mount Block
2 per machine**



I-15-1113

**Magazine Plate Guide Column
4 per machine**



I-15-1601

**Linear Bearing, 8 Separation, 1
Faulty, 1 Closing
10 per machine**

SEPARATION



I-15-1076

**Magazine Housing Shaft - Short
1 per machine**



I-15-1077

**Magazine Housing Shaft
1 per machine**



I-15-1047

**Separation Cam Arm
1 per machine**



I-15-1078

**Magazine Slide Arm
1 per machine**



I-15-0130

**Separation Pin Plate, 12 CT
2 per machine**



I-15-1840

**Du Bushing (separation pin plate)
4 per machine**

SEPARATION



I-15-0117

**Separation Pin
12 per machine**



I-15-0127R

**Suction Shoe-Right
1 per machine**



I-15-0128L

**Suction Shoe-Left
1 per machine**



I-15-0131N

**Vacuum Shoe Guide Column
4 per machine**

I-15-0131M

**Vacuum Shoe Guide Column Bolt
4 per machine**



I-15-0161

**Vacuum Shoe Guide Column
Bushing
4 per machine**



I-15-0161-S

**Vacuum Shoe Guide Column
Spring
4 per machine**

SEPARATION



I-15-1801

**Guide Column Wiper
4 per machine**



I-15-0153

**Separation Station Shaft
2 per machine**



I-15-1048

**Separation Arm Assembly Shaft
1 per machine**



I-15-1065

**Separation Cam
1 per machine**



I-15-1066

**Sorting Cam
1 per machine**

SEPARATION



I-15-1041

**Cam Lever Magazine
1 per machine**



I-15-1045

**Separation Lever Arm
1 per machine**



I-15-1118

**Magazine Lower Activating Rod
1 per machine**



I-15-1119

**Magazine Upper Activating Rod
1 per machine**



I-15-1618

**Ball Bearing, Magazine
2 per machine**



I-15-1625

**Rod End PHS10A, Separation
Drive
2 per machine**



I-15-1626

**Rod End PHS10LA, Separation
Drive
2 per machine**

CAPSULE CARRIER & GENEVA DRIVE

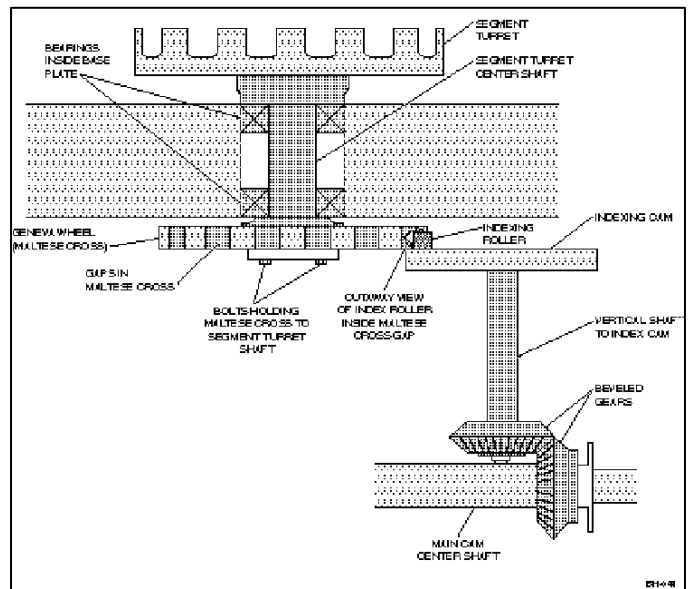
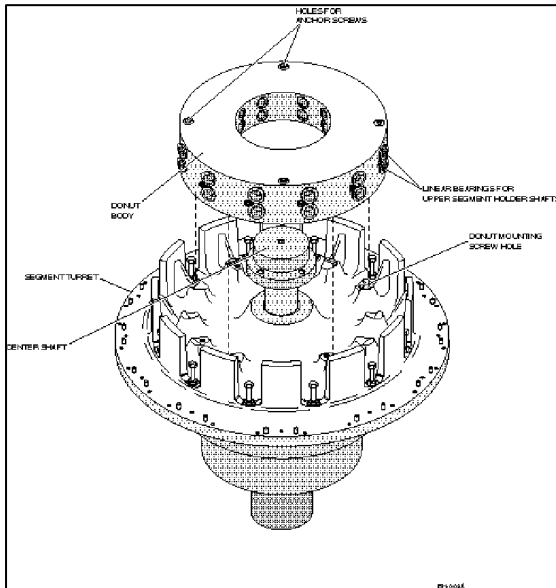
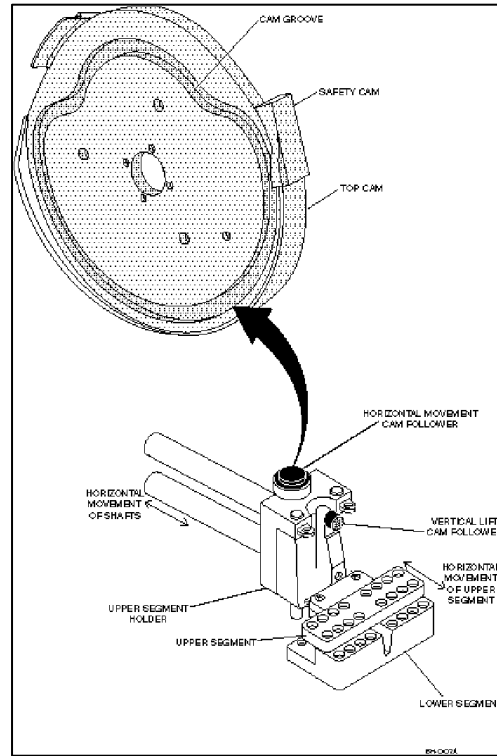
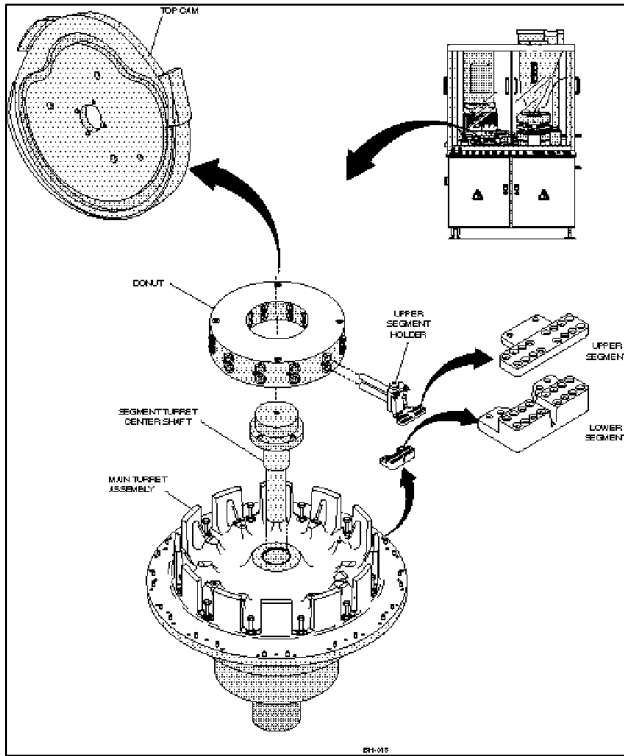

CAPSULE CARRIER & GENEVA DRIVE



I-15-1067

**Profile Cam
1 per machine**



I-15-1084

**Segment Separation Plate
1 per machine**



I-15-1615

**Roller and Thrust Bearing, Top
Cam and Inner Shaft
2 per machine**



I-15-1501

**Main Geneva Drive
1 per machine**



I-15-1069

**Indexing Cam
1 per machine**



I-15-1069-H

**Indexing Cam Hub
1 per machine**



I-15-1055-CG

**Brake Shoe Capsule Geneva
1 per machine**



I-15-1459

**Shoulder Bolt for Cap Geneva
Drive Hub
2 per machine**



I-15-1508

**Lock Arm Capsule Geneva Drive
1 per machine**



I-15-0133

**Station Holder Assembly
12 per machine**



I-15-0138

**Shaft Long
24 per machine**



I-15-0139

**Segment Return Spring
24 per machine**

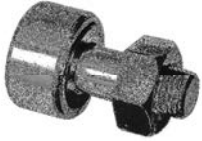

I-15-1622

**Cam Follower, Segment Carrier
12 per machine**



I-15-1600

**Linear Bearing, Segment Carrier
Core
48 per machine**



I-15-1802

**Station Holder Rod Wiper
24 per machine**

TAMPING AND POWDER DOSING

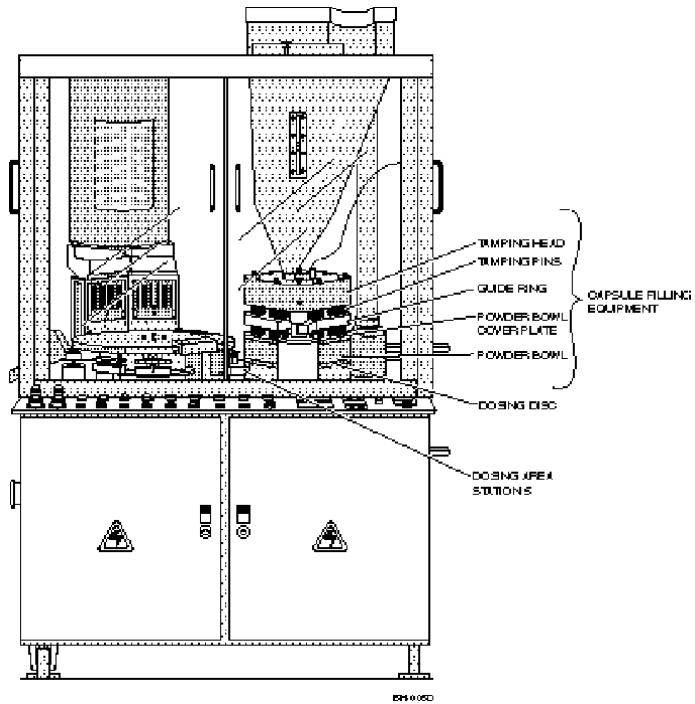
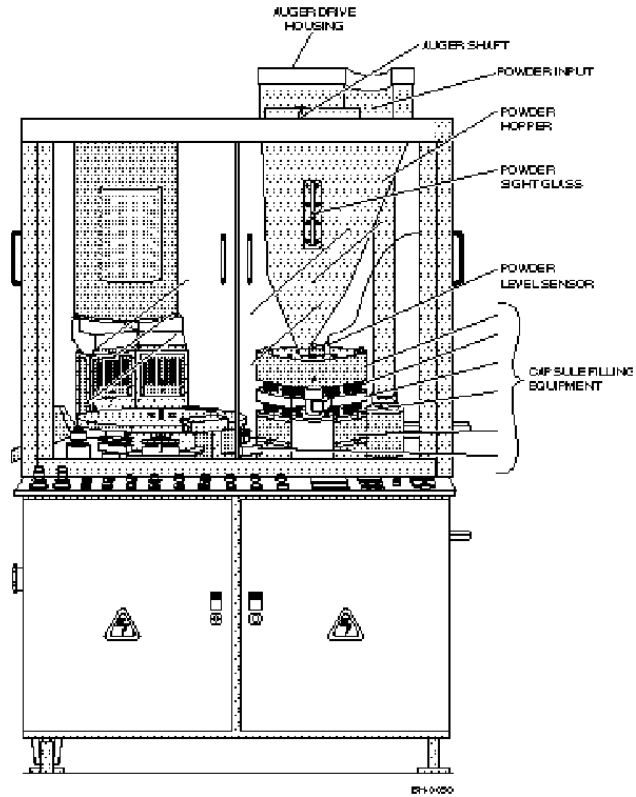

TAMPING AND POWDER DOSING

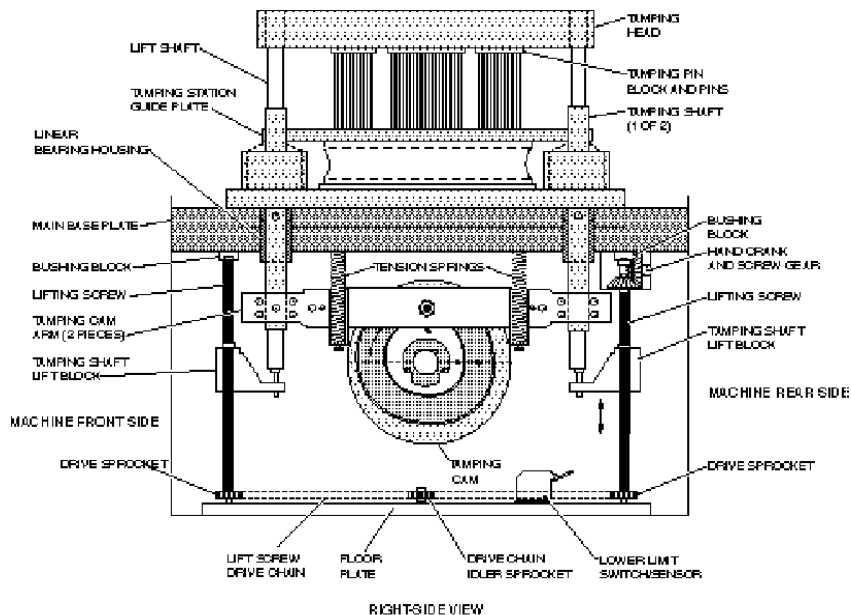
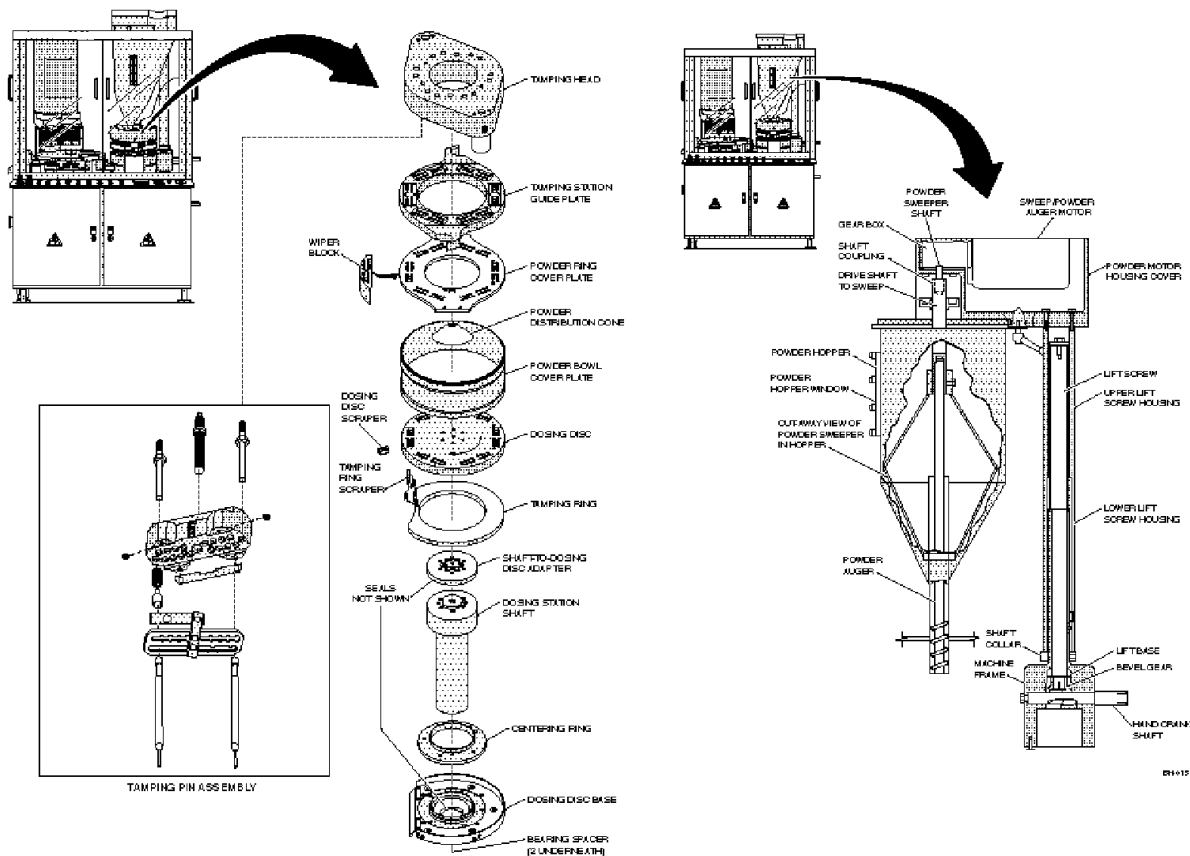

TAMPING AND POWDER DOSING



I-15-1097

**Powder Agitator Complete
1 per machine**



I-15-1267

**Auger Screw, Pitch 30.0
1 per machine**



I-15-1290

**Auger Screw, Pitch 2.0
1 per machine**



I-15-1020

**Tamper Block Housing
1 per machine**



I-15-1085

**Tamping Station Housing Shaft
2 per machine**

TAMPING AND POWDER DOSING



I-15-0155A

**Transfer Block Assembly
1 per machine**



I-15-0155

**Tamper Holding Block with Scale
and Spring
5 per machine**



I-15-0140-H

**Tamper Compression Spring-
Heavy
60 per machine**

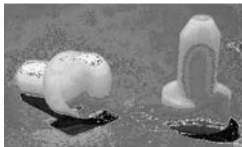

I-15-0141-D

**Tamper Pin Cap (Delrin)
60 per machine**



I-15-0157

**Spring Clip Lock
6 per machine**



I-15-0163

**Tamper Plate Spring Holder
6 per machine**



I-15-0146

**Tamper Adjusting Screw
5 per machine**

TAMPING AND POWDER DOSING



I-15-0149

**Turn Buckle Screw 10mm
2 per machine**



I-15-1086

**Tamper Block Guide Column
10 per machine**



I-15-1094

**Tamper Plate Slide Stop
12 Per machine**



I-15-1096S

**Tamper Guide Plate
1 per machine**

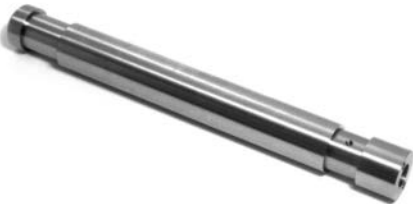

I-15-1007

**Tamping Shaft
2 per machine**



I-15-1841

**Du Bushing, Tamping Shaft
4 per machine**

TAMPING AND POWDER DOSING



I-15-1015

**Tamper Bearing Block
2 per machine**



I-15-1604

**Linear Bearing, Tamping
Columns
4 per machine**



I-15-1091

**Powder Ring Plate
1 per machine**



I-15-1262

**Powder Retaining Ring
1 per machine**

TAMPING AND POWDER DOSING

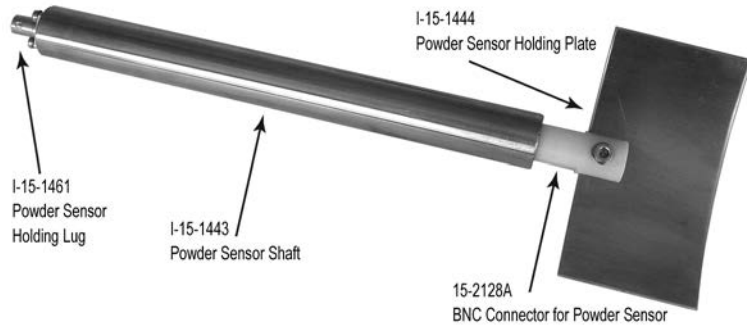

I-15-1443PSA
Powder Sensor Shaft
Probe Assembly

Consisting of:
I-15-1443
Powder Sensor Shaft

I-15-1444
Powder Sensor Holding Plate

I-15-1461 (Picture Error:Swap with i-15-1461)
Powder Sensor Holding Lug

I-15-2128A (Picture Error:Swap with i-15-1461)
BNC Connector for Powder
Sensor



I-15-1429
Powder Sensor Holding Collar
1 per machine



I-15-0142
Powder Wiper
1 per machine



I-15-0103S
Dosing Disc Scraper
1 per machine

TAMPING AND POWDER DOSING



I-15-0104
Tamping Ring
1 per machine

I-15-1100
Tamping Ring Scraper
1 per machine



I-15-1270

Vacuum Ring Cover Plate
1 per machine



I-15-1114

Vacuum Ring for Dosing Station
1 per machine



I-15-1450

Dosing Disc Mount Plate
1 per machine

TAMPING AND POWDER DOSING



I-15-0145

**Powder Geneva Drive
1 per machine**



I-15-1260

**Bearing Stud (Powder Station
Locking Arm & Geneva Drive)
2 per machine**



I-15-1070

**Dosing Cam
1 per machine**

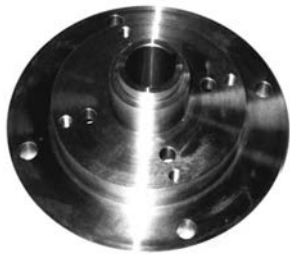

I-15-1070H

**Dosing Cam Hub
1 per machine**



I-15-1055PG

**Brake Shoe Base Powder Geneva
1 per machine**

TAMPING AND POWDER DOSING

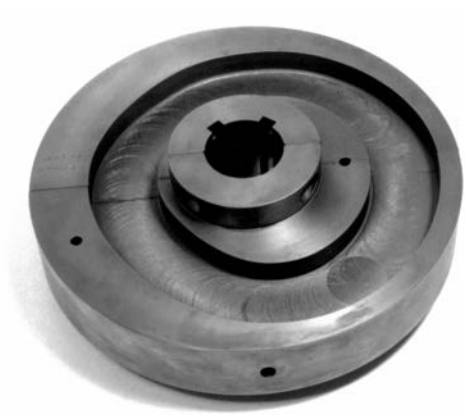

I-15-1062

**Tamping Cam
1 per machine**

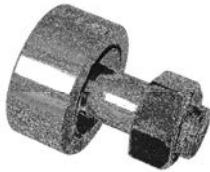

I-15-1621

**Cam Follower, Tamping Cam
2 per machine**



I-15-1068

**Tamping Cam Arm Set
1 per machine**



I-15-1759

**ENT 6 Powder Sensor
1 per machine**

FAULTY CAPSULE REJECTION

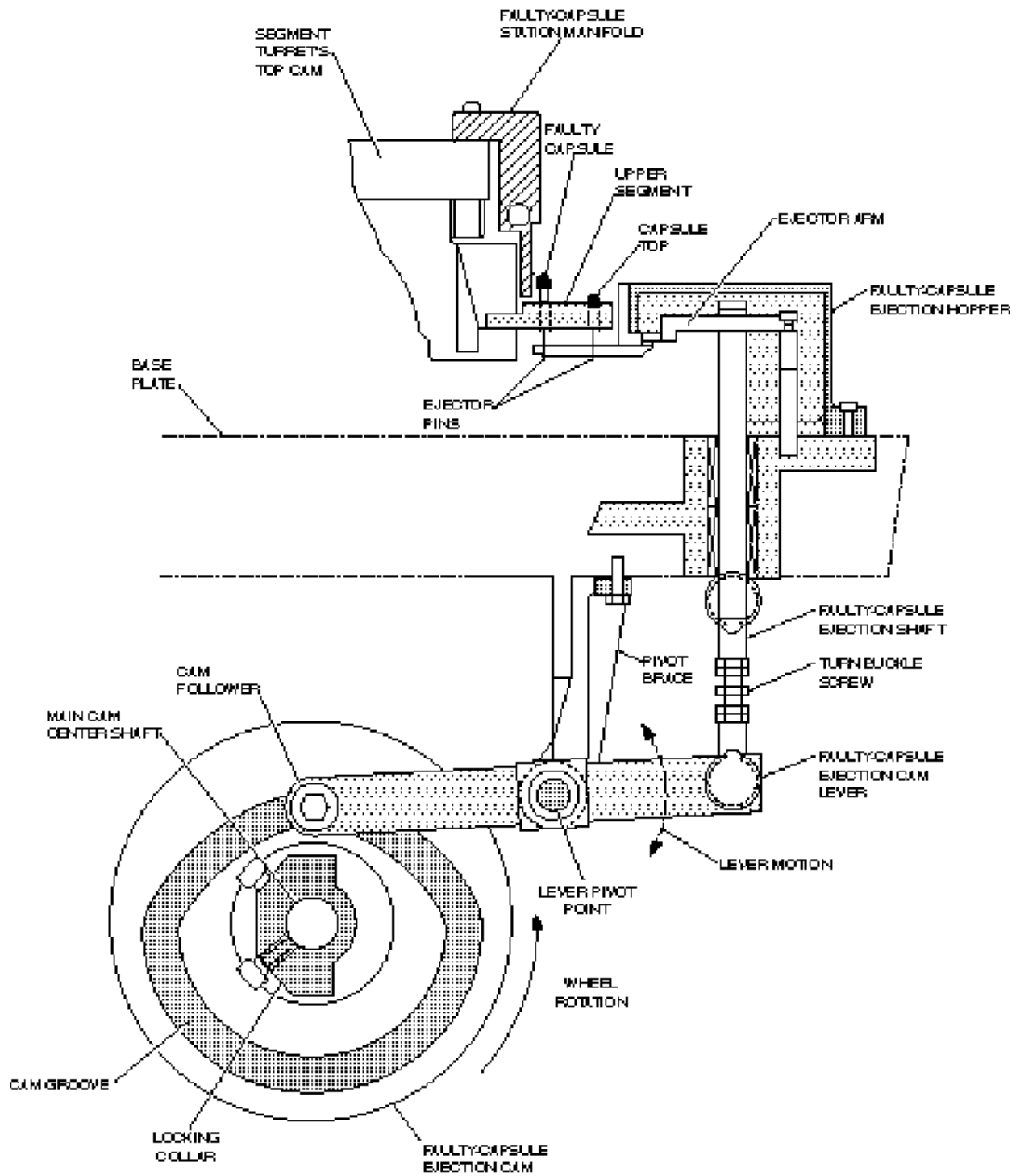

FAULTY CAPSULE



I-15-0132

**Selection Arm, 12 CT
1 per machine**



I-15-0151

**Faulty Station Drive Shaft
1 per machine**

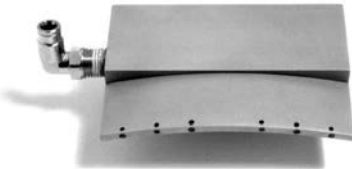

I-15-1083

**Faulty Ejection Station Manifold
1 per machine**



I-15-1060

**Faulty Capsule Ejection Cam
1 per machine**



I-15-1109

**Faulty Capsule Hopper
1 per machine**



I-15-1038

**Faulty Capsule Cam Lever
1 per machine**

CLOSING STATION

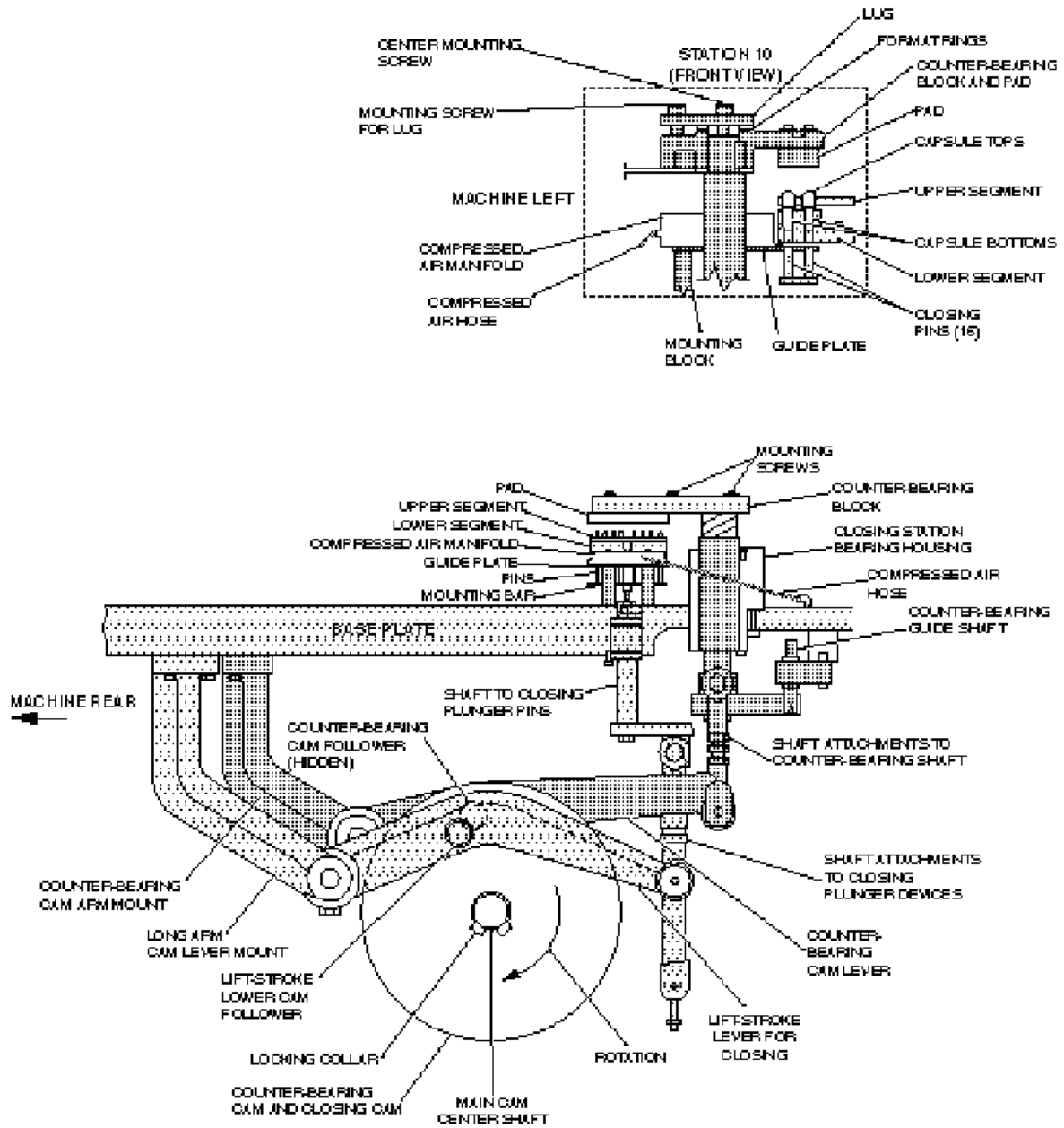

CLOSING

CLOSING PINS for 12 CT Machine

Part Number	Description	Mount Style	Size	Recommended Capsule Size	Guide Plate
I-15-0116CS-4.0	Closing Pin, Concave with Slots	Nut	4.0mm	"2", "3", "4", "5"	I-15-0125-4.0
I-15-0116CS -4.5	Closing Pin, Concave with Slots	Nut	4.5mm	"2", "3", "4"	I-15-0125-4.5
I-15-0116CS -5.0	Closing Pin, Concave with Slots	Nut	5.0mm	"1", "0"	I-15-0125-5.0
I-15-0116CS -5.5	Closing Pin, Concave with Slots	Nut	5.5mm	"0", "00"	I-15-0125-5.5
I-15-0116CS -6.0	Closing Pin, Concave with Slots	Nut	6.0mm	"0", "00"	I-15-0125-6.0
I-15-0116CS -6.5	Closing Pin, Concave with Slots	Nut	6.5mm	"00", "000"	I-15-0125-6.5

Please notice that the pins are sized by their diameter in mm, included above is Index's recommended size capsules that can be run with each size of closing pin.

EACH SIZE PIN REQUIRES A SPECIFIC GUIDE PLATE FOR THAT SIZE.

Most sizes in stock, delivery is 1-2 weeks.

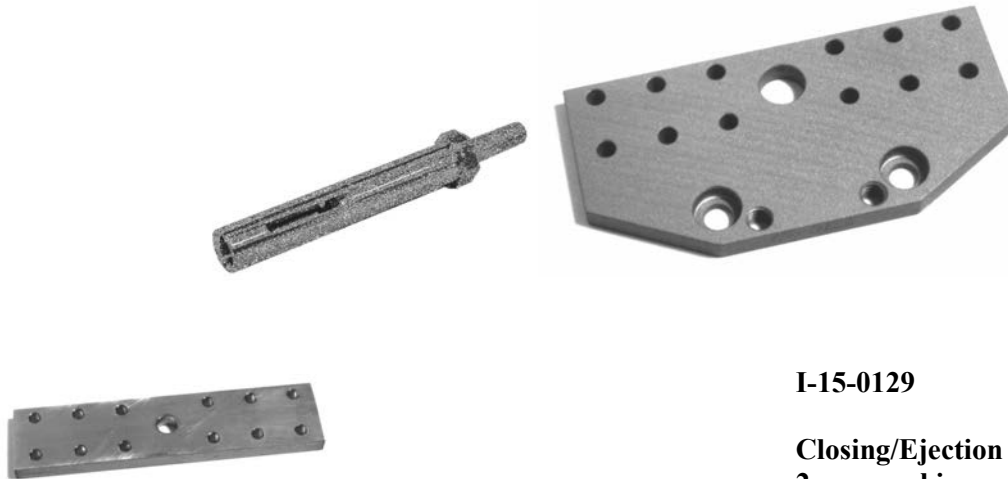

I-15-0129

**Closing/Ejection Pin Plate
2 per machine**

CLOSING



I-15-0120

**Upper Closing Housing
1 per machine**

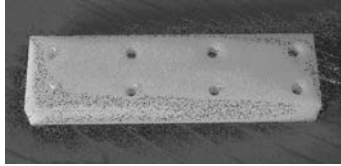

I-15-0120-01

**Upper Closing Delrin Lug
1 per machine**



I-15-0121

**Upper Closing Lug
1 per machine**

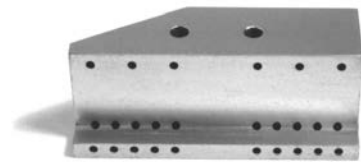

I-15-1050

**Closing Station Vacuum Block
1 per machine**



I-15-0164

**Closing Station Spacer
1 per set**



I-15-1089

**Upper Closing Spacer Set (3)
1 set per machine**



I-15-1016

**Closing Station Bearing Housing
1 per machine**

CLOSING



I-15-1026

**Upper Closing Drive Shaft
1 per machine**



I-15-0154

**Closing Station Shaft (old style)
2 per machine**



I-15-2301

**Closing Station Shaft (new style)
2 per machine**



I-15-1022

**Closing Shaft Bracket
1 per machine**



I-15-1023

**Upper Closing Shaft Bracket
1 per machine**



I-15-1024

**Upper Closing Shaft Bracket
1 per machine**



I-15-1036

**Upper Closing Shaft Guide
1 per machine**



I-15-1063

**Upper Closing Cam
1 per machine**

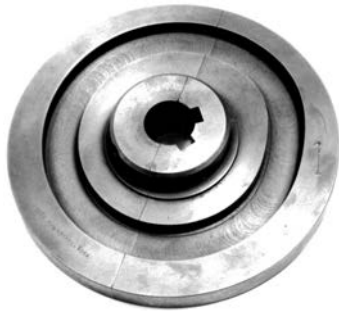

I-15-1064

**Lower Closing Cam
1 per machine**



I-15-1602

**Linear Bearing, Top Closing Shaft
2 per machine**



I-15-1028

**Closing Lift Stroke Lever
1 per machine**

MAIN DRIVE / MAIN SHAFT

MACHINE TOP

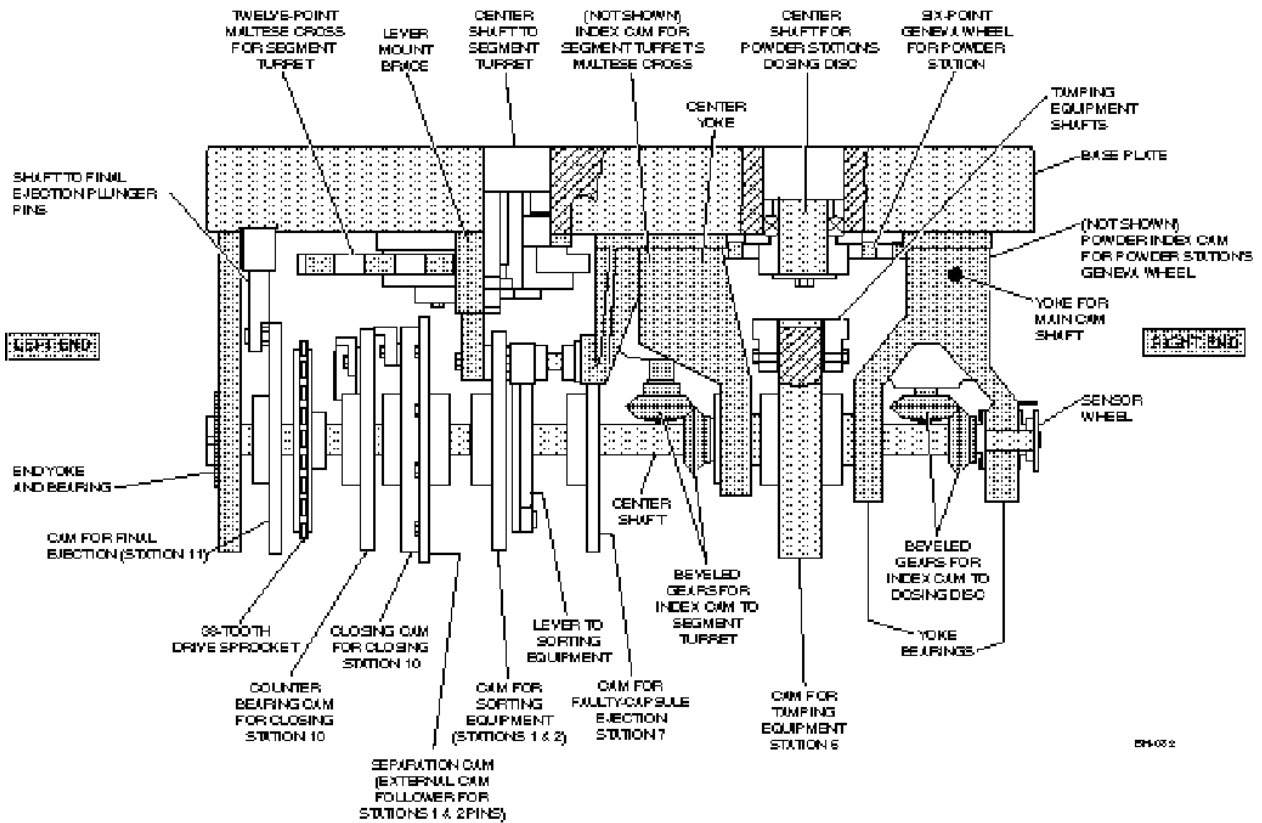

214-002

MACHINE FRONT VIEW

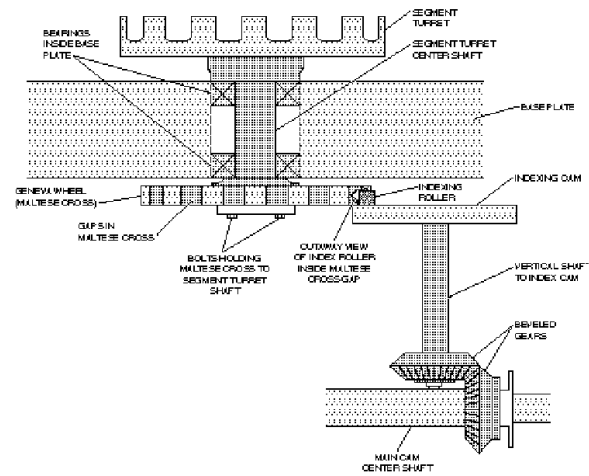
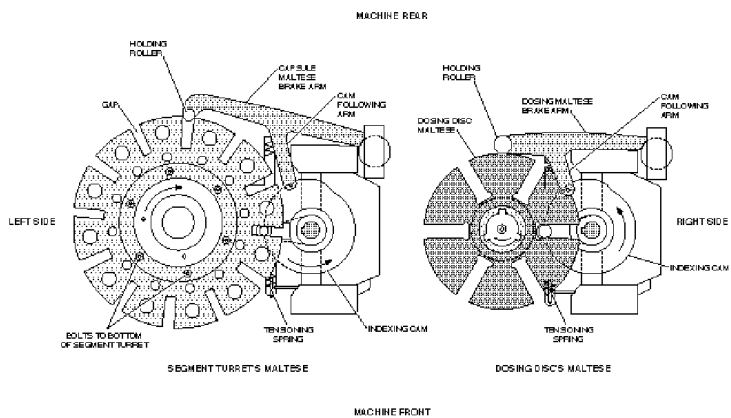

214-0

MAIN DRIVE / MAIN SHAFT



I-15-1112

**Main Shaft
1 per machine**



I-15-1057

**Yoke Shaft
2 per machine**



I-15-1057-K

**Yoke Shaft Key
2 per machine**



I-15-1104

**Main Shaft Bevel Gear (30mm
bore)
2 per machine**



I-15-1105

**Main Shaft Bevel Gear (40mm
bore)
2 per machine**

MAIN DRIVE / MAIN SHAFT

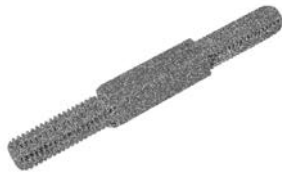

I-15-0150

**Turn Buckle Screw 12mm
3 per machine**



I-15-1021

**Main Shaft Casting
1 per machine**



I-15-1031

**Geneva Lever Arm
1 per machine**



I-15-1040

**Cam Arm Mount
1 per machine**



I-15-1620

**Ball Bearing, Double, Powder
Geneva Drive Crank
5 per machine**

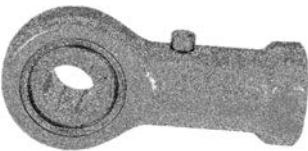

I-15-1627

**Rod End PHS12LA, Sorting and
Closing Drives
5 per machine**

MAIN DRIVE / MAIN SHAFT



I-15-1628

**Rod End, PHS12A, Sorting and Closing Drives
5 per machine**



I-15-1623

**Cam Follower, Geneva Locking Arms
2 per machine**



I-15-1624

**Cam Follower, Main Shaft Cams
6 per machine**



I-15-0148-size

**Spring Clip Screw
(each capsule size)**

**Long: 1 per machine
Medium: 2 per machine
Short: 4 per machine**



I-15-1603

**Linear Bearing, Main Table
9 per machine**



I-15-1803

**Rod Wiper, Main Table
9 per machine**

EJECTION

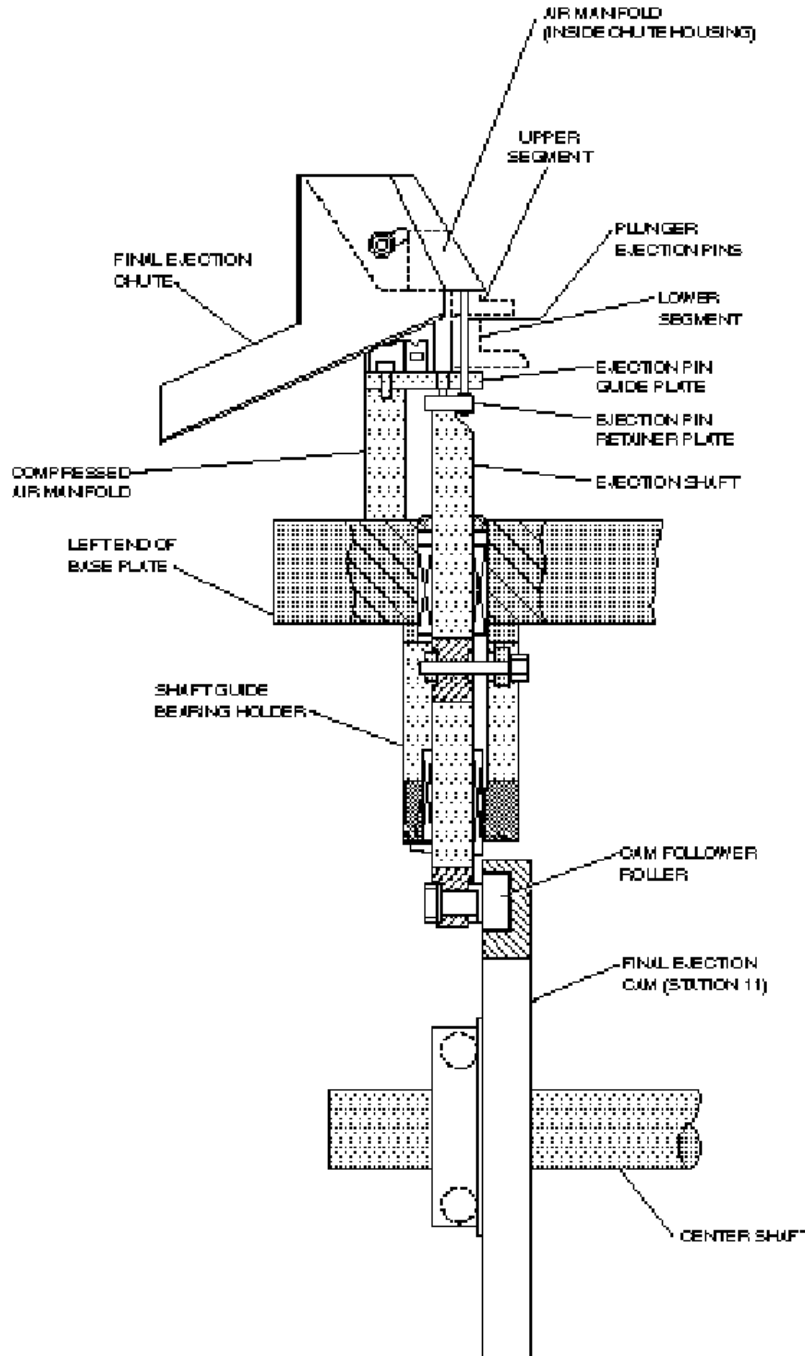

EJECTION



I-15-0129

**Closing/Ejection Pin Plate, 12 CT
2 per machine**



I-15-0118

**Ejection Pin, 12 CT
12 per machine**



I-15-0126

**Ejection Pin Guide Plate, 12 CT
1 per machine**



I-15-0152

**Ejection Station Drive Shaft
1 per machine**



I-15-1018

**Ejection Block
1 per machine**

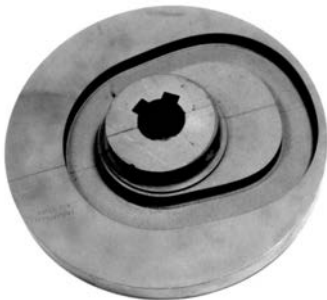

I-15-1061

**Ejection Cam
1 per machine**



I-15-1080

**Ejection Chute Manifold
1 per machine**

CLEANING

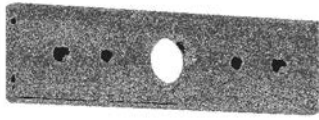

I-15-1435

**Cleaning Station Manifold Mount
Block
1 per machine**



I-15-1436

**Cleaning Station Manifold Shaft
1 per machine**



I-15-1451

**Cleaning Station Manifold
Assembly
1 per machine**



I-15-1451AT-2

**Air Tube
12 per machine**